

EN

User manual

Hob

# USER MANUAL

ZEI3921

**ZANUSSI**

## Contents

---

Safety information _____	2	Care and cleaning _____	7
Safety instructions _____	3	Troubleshooting _____	7
Product description _____	5	Installation _____	9
Daily use _____	5	Technical data _____	11
Helpful hints and tips _____	5	Environment concerns _____	11

Subject to change without notice.

## Safety information

---

Before the installation and use of the appliance, carefully read the supplied instructions. The manufacturer is not responsible if an incorrect installation and use causes injuries and damages. Always keep the instructions with the appliance for future reference.

### Children and vulnerable people safety

**⚠ Warning!** Risk of suffocation, injury or permanent disability.

- This appliance can be used by children aged from 8 years and above and persons with reduced physical, sensory or mental capabilities or lack of experience and knowledge if they are supervised by an adult or a person who is responsible for their safety.
- Do not let children play with the appliance.
- Keep all packaging away from children.
- Keep children and pets away from the appliance when it operates or when it cools down. Accessible parts are hot.
- If the appliance has a child safety device, we recommend that you activate it.
- Cleaning and user maintenance shall not be made by children without supervision.

### General Safety

- The appliance and its accessible parts become hot during use. Do not touch the heating elements.
- Do not operate the appliance by means of an external timer or separate remote-control system.

- Unattended cooking on a hob with fat or oil can be dangerous and may result in fire.
- Never try to extinguish a fire with water, but switch off the appliance and then cover flame e.g. with a lid or a fire blanket.
- Do not store items on the cooking surfaces.
- Do not use a steam cleaner to clean the appliance.
- Metallic objects such as knives, forks, spoons and lids should not be placed on the hob surface since they can get hot.
- If the glass ceramic surface is cracked, switch off the appliance to avoid the possibility of electric shock.

## Safety instructions

### Installation

 **Warning!** Only a qualified person must install this appliance.

- Remove all the packaging.
- Do not install or use a damaged appliance.
- Obey the installation instruction supplied with the appliance.
- Keep the minimum distance from the other appliances and units.
- Always be careful when you move the appliance because it is heavy. Always wear safety gloves.
- Seal the cut surfaces with a sealant to prevent moisture to cause swelling.
- Protect the bottom of the appliance from steam and moisture.
- Do not install the appliance adjacent to a door or under a window. This prevents hot cookware to fall from the appliance when the door or the window is opened.
- If the appliance is installed above drawers make sure that the space, between the bottom of the appliance and the upper drawer, is sufficient for air circulation.
- The bottom of the appliance can get hot. We recommend to install a non-combustible separation panel under the appliance to prevent access to the bottom.

ration panel under the appliance to prevent access to the bottom.

### Electrical connection

 **Warning!** Risk of fire and electrical shock.

- All electrical connections must be made by a qualified electrician.
- The appliance must be earthed.
- Before carrying out any operation make sure that the appliance is disconnected from the power supply.
- Use the correct electricity mains cable.
- Do not let the electricity mains cable tangle.
- Make sure the mains cable or plug (if applicable) does not touch the hot appliance or hot cookware, when you connect the appliance to the near sockets
- Make sure the appliance is installed correctly. Loose and incorrect electricity mains cable or plug (if applicable) can make the terminal become too hot.
- Make sure that a shock protection is installed.
- Use the strain relief clamp on cable.
- Make sure not to cause damage to the mains plug (if applicable) or to the mains cable. Contact the Service or an electrician to change a damaged mains cable.

- The electrical installation must have an isolation device which lets you disconnect the appliance from the mains at all poles. The isolation device must have a contact opening width of minimum 3 mm.
- Use only correct isolation devices: line protecting cut-outs, fuses (screw type fuses removed from the holder), earth leakage trips and contactors.

## Use

 **Warning!** Risk of injury, burns or electric shock.

- Use this appliance in a household environment.
- Do not change the specification of this appliance.
- Do not use an external timer or a separate remote-control system to operate the appliance.
- Do not let the appliance stay unattended during operation.
- Do not operate the appliance with wet hands or when it has contact with water.
- Do not put cutlery or saucepan lids on the cooking zones. They can become hot.
- Set the cooking zone to "off" after each use. Do not rely on the pan detector.
- Do not use the appliance as a work surface or as a storage surface.
- If the surface of the appliance is cracked, disconnect immediately the appliance from the power supply. This to prevent an electrical shock.
- Users with a pacemaker must keep a distance of minimum 30 cm from the induction cooking zones when the appliance is in operation.

 **Warning!** Risk of fire or explosion.

- Fats and oil when heated can release flammable vapours. Keep flames or heated objects away from fats and oils when you cook with them.
- The vapours that very hot oil releases can cause spontaneous combustion.

- Used oil, that can contain food remnants, can cause fire at a lower temperature than oil used for the first time.
- Do not put flammable products or items that are wet with flammable products in, near or on the appliance.
- Do not try to extinguish a fire with water. Disconnect the appliance and cover the flame with a lid or a fire blanket.

 **Warning!** Risk of damage to the appliance.

- Do not keep hot cookware on the control panel.
- Do not let cookware to boil dry.
- Be careful not let objects or cookware fall on the appliance. The surface can be damaged.
- Do not activate the cooking zones with empty cookware or without cookware.
- Do not put aluminium foil on the appliance.
- Cookware made of cast iron, aluminium or with a damaged bottom can cause scratches on the glass ceramic. Always lift these objects up when you have to move them on the cooking surface.

## Care and Cleaning

 **Warning!** Risk of damage to the appliance.

- Clean regularly the appliance to prevent the deterioration of the surface material.
- Do not use water spray and steam to clean the appliance.
- Clean the appliance with a moist soft cloth. Only use neutral detergents. Do not use abrasive products, abrasive cleaning pads, solvents or metal objects.

## Disposal

 **Warning!** Risk of injury or suffocation.

- Contact your municipal authority for information on how to discard the appliance correctly.
- Disconnect the appliance from the mains supply.

- Cut off the mains cable and discard it.

## Product description

### Cooking surface layout

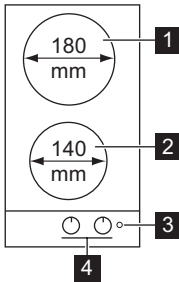

- 1** Cooking zone 1800 W
- 2** Cooking zone 1400 W
- 3** Power indicator
- 4** Control knobs

### Electric cooking zones control knobs

Symbol	Function
0	off position

Symbol	Function
1	minimum heat
9	maximum heat

## Daily use

**Warning!** Refer to the Safety chapters.

To switch on and increase the heat setting turn the knob clockwise. To decrease the heat setting turn the knob counter-clockwise. To switch off turn the knob to the 0.

Power indicator is activated when either of the zones are turned on, and will stay on until the cooking zones are switched off.

### Automatic switch off

The hob deactivates automatically if:

- All cooking zones are deactivated.
- You use incorrect cookware.

- You do not deactivate a cooking zone or change the heat setting. Before you use the hob again, the control knob must be set to the off position.

Heat setting	Automatic switch off timer
1 - 2	6 hours
3 - 4	5 hours
5	4 hours
6 - 9	1.5 hours

## Helpful hints and tips

**Warning!** Refer to the Safety chapters.

### Cookware for induction cooking zones

**i** In induction cooking a powerful electromagnetic field generates an almost instant heat inside the cookware.

### Cookware material

- **correct:** cast iron, steel, enamelled steel, stainless steel, a multi-layer bottom (marked as correct by a manufacturer).
- **not correct:** aluminium, copper, brass, glass, ceramic, porcelain.

## Cookware is correct for an induction hob if ...

- ... some water boils very quickly on a zone set to the highest heat setting
- ... a magnet pulls on to the bottom of the cookware.

 **The bottom of the cookware** must be as thick and flat as possible.

Cookware dimensions: induction cooking zones adapt to the dimension of the bottom of the cookware automatically to some limit. But the minimum diameter of the magnetic part of the bottom of the cookware is in relation to the diameter of the cooking zone:

Cooking zone	Minimum diameter of cookware
Front	120 mm
Rear	145 mm

## Energy saving

-  If possible, always put the lids on the cookware.
- Put cookware on a cooking zone before you start it.

## Examples of cooking applications

The data in the table is for guidance only.

Heat setting	Use to:	Time	Hints
1	Keep cooked foods warm	as required	Cover
1 - 2	Hollandaise sauce, melt: butter, chocolate, gelatine	5 - 25 min	Mix occasionally
1 - 2	Solidify: fluffy omelettes, baked eggs	10 - 40 min	Cook with a lid on
2 - 3	Simmer rice and milkbased dishes, heating up ready-cooked meals	25 - 50 min	Add at least twice as much liquid as rice, stir milk dishes part way through
3 - 4	Steam vegetables, fish, meat	20 - 45 min	Add a few tablespoons of liquid
4 - 5	Steam potatoes	20 - 60 min	Use max. ¼ l water for 750 g of potatoes
4 - 5	Cook larger quantities of food, stews and soups	60 - 150 min	Up to 3 l liquid plus ingredients
6 - 7	Gentle fry: escalope, veal cordon bleu, cutlets, rissoles, sausages, liver, roux, eggs, pancakes, doughnuts	as required	Turn halfway through
7 - 8	Heavy fry, hash browns, loin steaks, steaks	5 - 15 min	Turn halfway through
9	Boil large quantities of water, cook pasta, sear meat (goulash, pot roast), deep fry chips		

## Operating noises

### If you can hear

- cracking noise: cookware is made of different materials (Sandwich construction).
- whistling: you use one or more cooking zones with high power levels and the cook-

ware is made of different materials (Sandwich construction).

- humming: you use high power levels.
- clicking: electric switching occurs.
- hissing, buzzing: the fan operates.

**The noises are normal and do not refer to any defects.**

## Information on acrylamides

**Important!** According to the newest scientific knowledge, if you brown food (specially the one

which contains starch), acrylamides can pose a health risk. Thus, we recommend that you cook at the lowest temperatures and do not brown food too much.

## Care and cleaning

 **Warning!** Refer to the Safety chapters.

Clean the appliance after each use.  
Always use cookware with clean bottom.

 **Warning!** Before any maintenance or cleaning can be carried out, you must disconnect the hob from the electricity supply.

 The hob is best cleaned while it is still warm, as spillage can be removed more easily than if it is left to cool.

 **Warning!** Sharp objects and abrasive cleaning agents will damage the appliance.

For your safety, do **not** clean the appliance with steam blasters or high-pressure cleaners.

 Scratches or dark stains have no effect on how the appliance operates.

### Removing the dirt:

1. Use the fine scouring powder or a scouring pad to remove the dirt.

2. Clean the appliance with a damp cloth and some detergent.
3. Heat the hotplate to a low temperature and leave to dry.
4. To maintain the hotplates, wipe the plates with a drop of olive oil on a kitchen towel to prevent rust.

**Important!** For stainless steel edges of the hob use cleaner for stainless steel.

 The stainless steel edge of the plate can be slightly discoloured as a result of the thermal load.

The stainless steel can become tarnished if it is too much heated. Refer to this you must not cook with potstones, earthenware pans or cast iron plates. Do not use aluminium foil to prevent damage the top during operation.

## Troubleshooting

Problem	Possible cause and remedy
The appliance does not operate.	<ul style="list-style-type: none"><li>▪ Examine the fuse in the electrical system of the house in the fuse box. If the fuses blow time after time, speak to an authorised electrician.</li></ul>
The plate does not heat up.	<ul style="list-style-type: none"><li>▪ Make sure that you plug in the appliance and switch the electrical supply.</li><li>▪ Make sure that you turn correct control knob.</li><li>▪ Examine the fuse in the electrical system of the house in the fuse box. If the fuses blow time after time, speak to an authorised electrician.</li></ul>

Problem	Possible cause and remedy
Results of plate are not satisfactory.	<ul style="list-style-type: none"> <li>Make sure that plate is clean and dry.</li> <li>Make sure that the cooking pan is the correct size for the plate.</li> <li>Make sure that cooking pan has a flat bottom.</li> <li>Make sure that the setting is correct for type of cooking.</li> </ul>
Acoustic warning (double acoustic signal) sounds.	<ul style="list-style-type: none"> <li>The pot is not suitable. Use suitable cookware.</li> <li>No cookware on the plate. Place cookware on the plate.</li> <li>The diameter of the bottom of the cookware is too small for the plate.</li> <li>Move onto a smaller plate. Use suitable cookware.</li> </ul>

If there is a fault, first try to find a solution to the problem yourself. If you cannot find a solution to the problem yourself, speak your dealer or the local Service Force Centre.

**i** If you operated the appliance incorrectly, or the installation was not carried out by a registered engineer, the visit from the customer service technician or dealer may not take place free of charge, even during the warranty period.

**These data are necessary to help you quickly and correctly. These data are available on the supplied rating plate.**

- Model description .....

- Product number (PNC) .....
- Serial Number (S.N.) .....

Use the original spare parts only. They are available at Service Force Centre and approved spare parts shops.

### Labels supplied with the accessories bag

Stick the adhesive labels as indicated below:

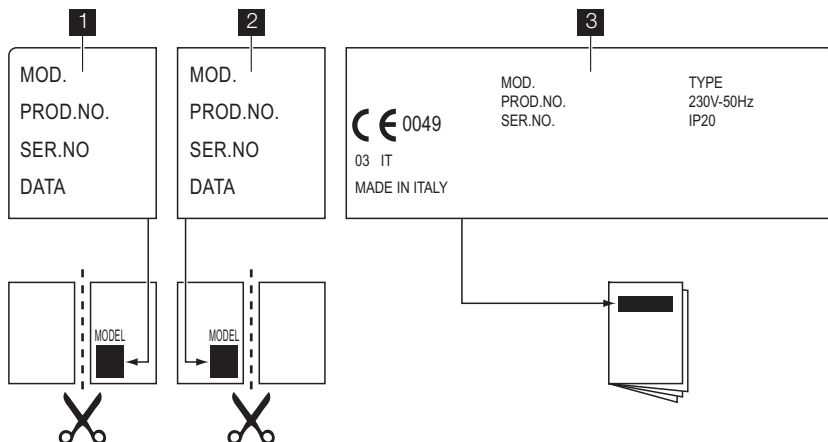

**1** Stick it on Guarantee Card and send this part

**2** Stick it on Guarantee Card and keep this part

**3** Stick it on instruction booklet



# Installation

 **Warning!** Refer to the Safety chapters.

## Installation

 **Warning!** Read and follow the instructions carefully. There is a risk of injury or damage to the appliance.

- Make sure that there is no damage to the appliance from the transportation. Do not connect a damaged appliance. Speak to the supplier if necessary.
- Install built-in appliances only after you assemble the appliance into correct built-in units and work surfaces. Make sure that built-in units and surfaces obey the standards.
- Obey all orders and standards in force in the country where you use the appliance (safety standards, recycling standards, electrical safety standards etc.)

 **Warning!** Risk of injury from electrical current.

- The electrical mains terminal is live.
- Make electrical mains terminal free of voltage.
- If the fixing bracket is near to the terminal block, do not let the connection cable come in contact with the edge of the bracket.

## Electrical connection

- Do not pull the mains cable to disconnect the appliance. Always pull the mains plug (if applicable).
- The appliance must not be connected with an extension cable, an adapter or a multiple socket. There is a risk of fire.
- Do not let the power cable to heat up to a temperature of more than 90° C. The cable should be guided by means of clamps fixed to the side of the cabinet, in order to avoid any contact with the equipment beneath the cooktop.
- Make sure that there is access to the mains plug after the installation.

## Electrical Requirements

Permanent electrical installation must agree with the latest I.E.E. Regulations and local Electricity Board regulations. For your own safety the installation must be done by a qualified electrician (e.g. your local Electricity Board, or a contractor who is on the roll of the National Inspection Council for Electrical Installation Contracting [NICEIC]).

 The manufacturer refuses to be held responsible, if these safety measures are not abided by.

### Supply connections:

This hob has to be connected to 230 — 240 V (50 Hz) electricity supply.

Before carrying out the connection, make sure:

1. The limiter valve and the electrical system can take the appliance load (see the rating plate)
2. The supply system is equipped with an efficient earth connection in compliance with the current standards and regulations
3. The outlet or omnipolar switch used for connection is easily accessible with the appliance installed.

The appliance is supplied with a 3 core flexible power cable requiring a 13 amp plug fitted with a 13 amp or 3 amp fuse dependent on the load. You must purchase and install the plug.

The wires in the cord are coloured as follows:

Green and yellow	- Earth
Blue	- Neutral
Brown	- Live

### Replacement of the connection cable

1. Connect the green and yellow (earth) wire to the terminal which is marked with the letter 'E', or the earth symbol , or coloured green and yellow.
2. Connect the blue (neutral) wire to the terminal which is marked with the letter 'N' or coloured blue.

3. Connect the brown (live) wire to the terminal which is marked with the letter 'L' and is always connected to the network phase.

There must be no cut or stray strands of wire present. The cord clamp must be correctly attached to the outer sheath.

**i** To replace the connection cable use only H05V2V2-F T90 or equivalent type. Make sure that the cable section is applicable to the voltage load and the working temperature. The yellow/green earth wire (B) must be approximately 2 cm longer than the live and neutral wire (A).

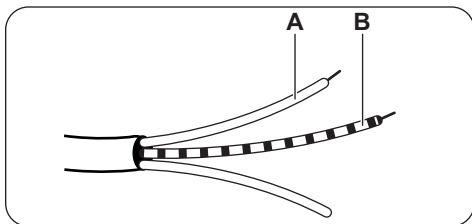

**Warning!** A cut off plug inserted into a 13 amp socket is a serious safety (shock) hazard. Ensure that the cut off plug is disposed of safely.

**Important!** The replacement of electric cable must be carried out exclusively by the service force centre or by personnel with similar competencies, in accordance with the current regulations.

### Building in

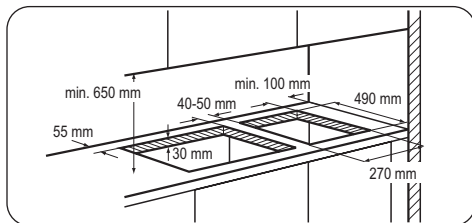

If several 30 cm hobs are to be installed side by side into the same cut out, an assembly kit including a support side bracket and supplementary seals is available at our Service Centres.

The relevant installation instructions are supplied within the kit package.

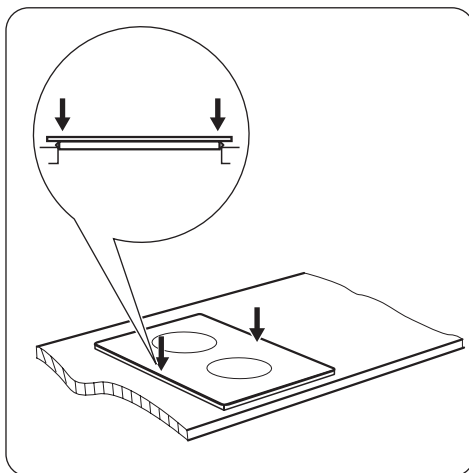
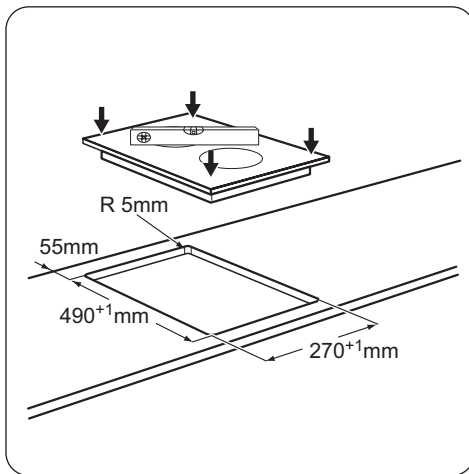

### Possibilities for insertion

#### Kitchen unit with door

The panel installed below the hob must be easy to remove and let an easy access in case a technical assistance intervention is necessary.

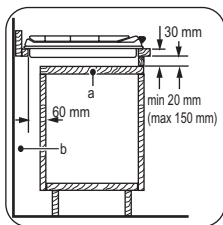

- A) Removable panel
- B) Space for connections

### Kitchen unit with oven

The hob recess dimensions must obey the indication and the kitchen unit must be equipped

## Technical data

### Hob dimensions

Width:	290 mm
Length:	510 mm

### Hob recess dimensions

Width:	270 mm
Length:	490 mm

## Environment concerns

The symbol  on the product or on its packaging indicates that this product may not be treated as household waste. Instead it should be taken to the appropriate collection point for the recycling of electrical and electronic equipment. By ensuring this product is disposed of correctly, you will help prevent potential negative consequences for the environment and human health, which could otherwise be caused by inappropriate waste handling of this product. For more detailed

with vents to let a continuous supply of air. The electrical connection of the hob and the oven must be installed separately for safety reasons and to let easy remove oven from the unit.

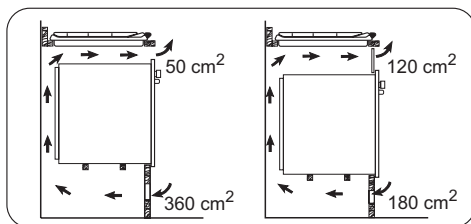

### Hot plate rating

Rear cooking zone 180 mm	1.8 kW
Front cooking zone 140 mm	1.4 kW
Total rating	3.2 kW
Electric supply	230 V ~ 50 Hz

information about recycling of this product, please contact your local council, your household waste disposal service or the shop where you purchased the product.

### Packaging material

 The packaging materials are friendly to the environment and can be recycled. The plastic components are identified by marking: >PE<, >PS<, etc. Discard the packaging materials as household waste at the waste disposal facilities in your municipality.



[www.zanussi.com/shop](http://www.zanussi.com/shop)



397297701-B-342012